CUMULATIVE EFFECT OF SUGAR SYRUP ON COLONY SIZE OF HONEYBEES, *Apis mellifera adansonii* Latreille (1804) (HYMENOPTERA: APIDAE) IN ARTIFICIAL BEEHIVES

K.A. FASASI

Department of Biological Sciences, College of Science, Engineering and Technology
Osun State University, P. M. B. 4494, Osogbo, Osun State, Nigeria.

E-mail: kamiluayofasasi@yahoo.com

Tel: +2348032585328

ABSTRACT

Cumulative effect of sugar syrup (nectar supplement) on colony size of honeybees, *Apis mellifera adansonii* Latreille (1804) (Hymenoptera: Apidae), in the Biological Garden of University of Lagos, was studied. The population density (colony size) of honeybees in each hive was monitored monthly for two years. In one treatment of two replicates, 0.1g/ml of sugar syrup was introduced using 350ml jar with the aid of wooden tray feeders, while the second treatment of another two replicates lacked sugar syrup. Colony size was estimated in each of the replicate using gravimetric method. The pattern of colony population of the honeybees fed with sugar syrup was similar to those without sugar syrup initially but unequal during most of the period of observation. The population size of the colonies fed with sugar syrup remained significantly higher ($p < 0.05$) than those that were not fed with sugar syrup after the first six months of the commencement of the study despite their similar pattern of fluctuation. The practical implication of this study was that regular feeding of sugar syrup at appropriate time to honeybee colonies for long duration (2 years) helped to sustain bee colonies with optimum population for nectar and pollens gathering from the wild against active season, hence increasing colony productivity during nectar flow period.

Key Words: Colony size, Cumulative effect, Honeybees, Sugar syrup and Supplemental feeding.

INTRODUCTION

Honeydews, nectar and pollens are natural food of adult honeybees which are collected by honeybees at the tips of buds and bases of natural flowers which the bees depend upon for their source of energy (Haydak, 1970, Johansson and Johansson, 1976 and Fasasi *et al.*, 2007). Nectar contains low to moderate concentration of sugar and honeybees dehydrate nectar to produce honey which is stored in the combs. Pollens are also obtained from flowers by bees to feed members of the colonies including broods.

Honeybees derived their protein, vitamins, minerals and some carbohydrates from pollens (Mussen, 2005a and b). It was emphasized that no single pollen source provides all their nutritional needs, so honeybees explore different botanical sources to have variety of pollens to remain healthy and produce the royal jelly required to feed the queen, rear brood and possibly store excess in form of honey during bountiful harvest. Regular colony inspection of beehives may reveal acute shortage of nectar and pollens in beehives which may be as a result of bad

weather prohibiting foraging activities or shortage of food in the environment. When it is observed that honeybees are short of honeydews, nectar and pollens from their surroundings, it is sometimes necessary to feed nectar or pollen substitutes (such as sugar syrup or glucose candy) to bee colonies particularly when they do not have surplus in the colonies to sustain them during dearth period (Fasasi *et al.*, 2007). Aside sugar syrup, honeybees can also be fed with various foodstuffs such as candy, brewer's yeast, soybean, flour, wheat, fructose, corn syrup (Standifer, 2005 and Fasasi *et al.*, 2007) and mahua flower (*Bassia latifolia* Roxb) syrup (Singh and Upadhyay, 2008) to supplement inadequate supplies of nectar and or pollens from the Wild. In dearth period, colony population of honeybees diminishes and poses serious threat to Beekeepers and honey industry. As a result, bee colonies may die or abscond from their domicile hives due to scarcity of sustainable and quality food. Under such conditions Beekeepers normally feed their honeybee colonies with pollen substitutes to sustain them throughout the dearth period (Goodwin, 1997 and Singh and Upadhyay, 2008). In advanced countries such as Britain, Israel, America and India, commercial Bee keepers feed their bee colonies with pollen and nectar supplements such as sugar syrup to develop and sustain the colonies with optimum populations for (1) nectar flow period, (2) pollination of crops, (3) autumn and spring divisions, (4) queen and package-bee production and (5) overwintering (Standifer *et al.*, 1978 and Fasasi *et al.*, 2007), but Nigeria Bee keepers are not well disposed to these acts and the numerous advantages. In India, Feeding colonies of honeybees (*Apis mellifera*) with syrup made from the flowers of mahua (*Bassia latifolia* Roxb) was found to enhance brood

area and number of frames occupied by honeybees during times of dearth (Singh and Upadhyay, 1999). Goodwin (1997) emphasized that feeding sugar syrup was one of the earliest management techniques developed for improving honeybee (*Apis mellifera*) pollination of crops. The basic approach to sugar feeding have been used to improve pollination which include (i) attracting bees to crop by spraying it with sugar syrup (ii) redirecting bees to a crop by feeding scented syrup either inside or outside their hives (iii) feeding syrup inside hive to increase the number of pollen gatherers (Goodwin, 1997). Goodwin and Houten (1991) also observed and concluded that colonies fed three litres of sugar syrup every three days collected significantly more kiwifruit pollens than colonies fed one liter every three days. Despite the above mentioned advantages of supplemental feeding of bee colonies, well managed colonies require regular or continuous supplemental feeding as the need arises for continuous survival of bee colonies (Fasasi *et al.*, 2007). In Nigeria, between June and September, particularly in South-West zone, there is need to feed honeybees with nectar supplement because the wet season reduces foraging activities of honeybees which in turn affects colony productivity (Fasasi and Malaka, 2005; Fasasi *et al.*, 2007). Fasasi *et al.*, (2007) explained that honeybees can be fed on stored honey or brown (unrefined) sugar called candy or white (refined) sugar or any acceptable pollen or nectar supplements in the hives using either frame (Division board) feeders, or the friction top containers or any suitable container with lid or inner feeders. Most part-time and full-time beekeepers in Nigeria, sparingly feed nectar or pollen supplements to their bee colonies particularly in wet seasons because they lack the awareness of the beneficial effect of supplemental feeding of honeybees and the technique of how

to feed their colonies. Hence, reducing honey yield during the nectar flow season probably as a result of low population density. This study focused on cumulative effect of sugar syrup on colony size of honeybees, *Apis mellifera adansonii*.

MATERIALS AND METHODS

Study site

The study site was the Biological Garden, located by the lagoon front, University of Lagos Campus which has an estimated area of about 802 acre situated on an extensive Lagoon front in the central part of Lagos metropolis. The campus is located between latitudes 06° 30' 15"N and 06° 31' 20" N and longitudes 3° 23' 05"E and 3° 24' 20" E.

Culturing of Honeybees

Honeybees were reared and cultured in five single-chambered artificial beehives called Langstroth hives (Figures 1 and 2) (Plates 1 and 2) constructed with hardwood (*Terminalia macroptera* – black afara) with iron roofing sheets gave rise to bee cultures. Each beehive measured 475mm and

400mm in length and width respectively with height of 475mm, and were placed on each stand measuring 500mm in height, 400mm x 400mm in length and breadth respectively. These beehives were naturally colonized by the honeybees from the wild using baits. These cultures serve as stock for this experiment. Four new set of colonies were established by dividing the five old colonies into ten new bee colonies. Of which the new four hives were selected (A, B, C and D) for the study. The colonies of *Apis mellifera adansonii* in new four hives were allowed to acclimatize for one year, after which sugar syrup administration on the colonies commenced.

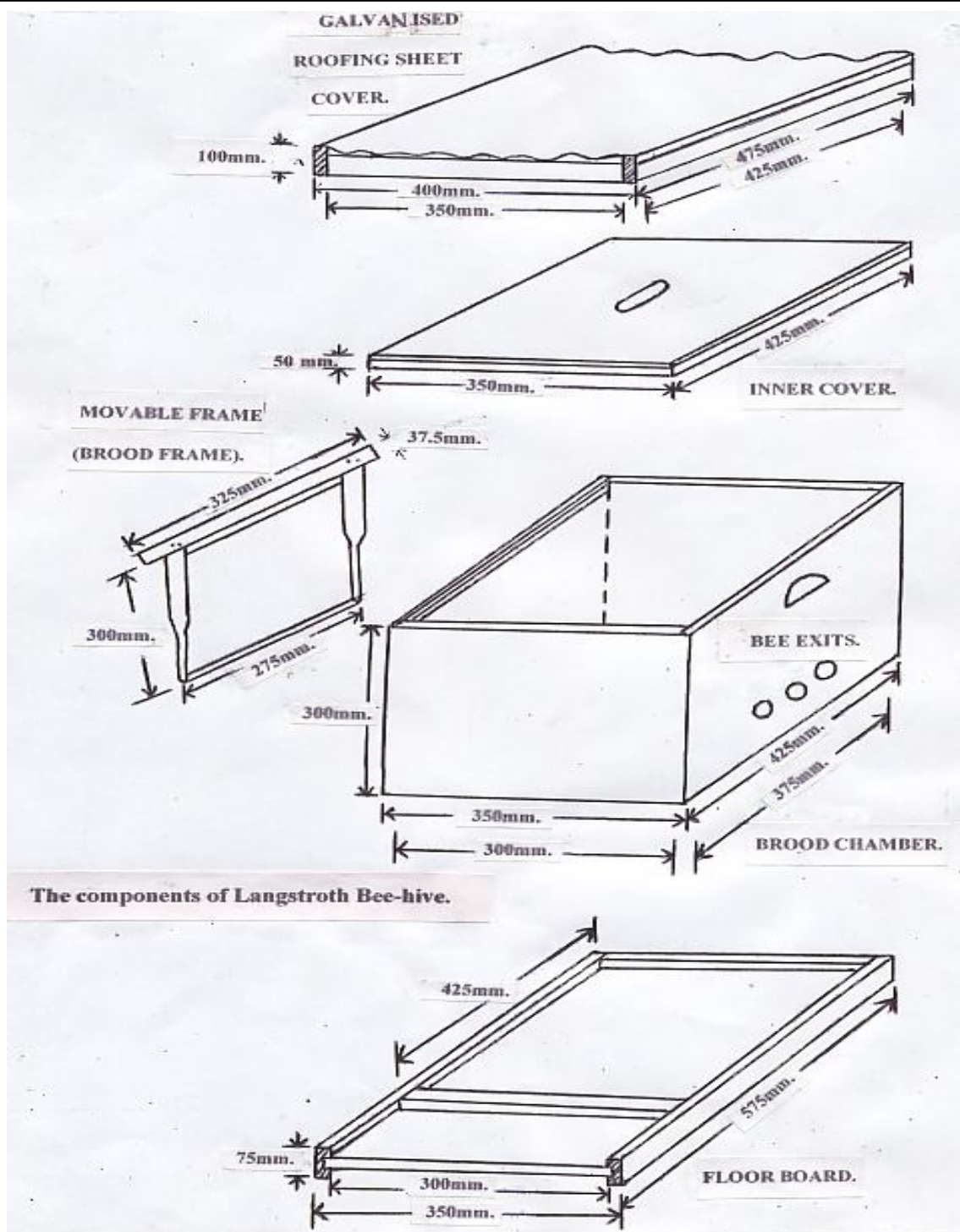

Figure 1: Sectional diagram of Langstroth beehive (Fasasi *et al.*, 2007)

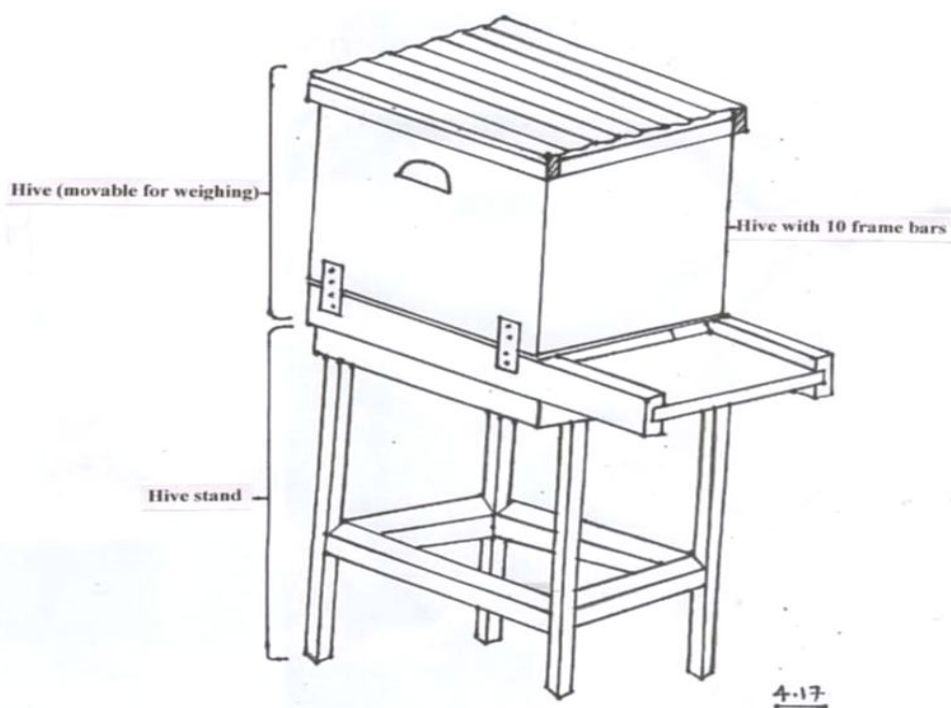

Figure 2: A set up of Langstroth beehive (Fasasi, 2008)



Plate 1: Bee-keeping Site with colonized Langstroth beehives at Biological Garden, University of Lagos Campus (Fasasi, 2008)



Plate 2: Colonized Langstroth beehive (Fasasi, 2008)

Administration of sugar syrup to colonies of *A. mellifera adansonii*

This experiment was set up using materials from established bee colonies. In each treatment, the hive was set up as follows. However, in each case only 24day old queens were used to start the fresh progeny to form new colonies in each treatment consisting of the following. In one treatment, 0.1g/ml of sugar syrup was introduced using 350ml jar with the aid of a wooden tray feeder, while the second treatment lacked sugar syrup. Each of the two treatments was replicated twice (in two separate hives). Bee population in each replicate hive was estimated once every month for a period of 24 months (2 dry and wet seasons alternatively) by estimating bee colony size as described below. The data were subjected to analysis of variance at 5% level of significance.

Procedure for estimating bee population in a colonized hive:

Bee population estimate in a colonized hive (each replicate) was carried out monthly using adapted gravimetric method of Farrar (1937) and Fresnaye and Lensky, (1961) as

follows:

{a} General Procedures:

Before setting up the hive (i.e. before colonization), all the ten empty frame bars of each hive were weighed individually and collectively, after which the hive together with all its ten frame bars was also weighed as a unit (Y). After colonization, bee population was estimated by using a net mesh (2mm) to screen off the entrance of the hive at sunset (5.00 - 7.00 p.m.), when most of the bees were inside, before reweighing the hive plus bee colony (K). After this, the hive was opened and each frame bar with associated combs, honey and broods were reweighed using a spring balance (H). Following this, 5 sub-samples of bees were taken from the brood chamber in a cup of known weight (P) and weighed individually to determine the mean weight of the number of bees in each cup. By counting the number of bees, after hypnotizing, in each cup (sub-sample of bees), the weight of one bee (X) was obtained by dividing the sub-sample's weight of bees only (wt. of bees + cup – wt. of cup) by the number of bees in the cup.

(b) Calculation of the estimated bee population was carried out after weighing as follows:

Obtaining weight of bee colony per hive (culture):

Wt. of empty hive + all 10 empty frame bars weighed individually = Y

Wt. of bee colony + hive + 10 frame bars with combs + broods + honey = K

Wt. of 10 frame bars + combs + broods + honey = H

Wt. of bee colony + hive = K - H

Wt. of empty hive = Y - Wt. of 10 empty frame bars (W) = L

Wt. of bee colony = (K - H) - L

Mean weight of one bee in bee colony:

Mean wt. of cup = P

Mean wt. of cup + mean wt. sub-sample of bees = Q

Mean wt. of sub-sample of bees = Q - P

Mean wt. of one bee = $\frac{Q - P}{N} = X$

Where 'N' is the mean number of bees per cup

Calculation of Estimated bee population:

$$\text{Estimated Population of bees in each colony} = \frac{\text{Wt. of bee colony}}{\text{Mean wt. of one bee}} = \frac{(K - H) - L}{\frac{Q - P}{N}}$$

The above described method (gravimetric method) of estimating bee population was adopted for easy understanding and practice by Nigeria Bee Keepers rather than using Capture-Mark and Recapture method of estimating insects' population which was assumed to be more scientific for the Nigeria Non-literate Bee Keepers when this experiment was designed.

RESULTS

The pattern of fluctuation of colony population of *A. mellifera adansonii* fed with sugar syrup was similar to those without sugar syrup but unequal during most of the period of observation (Figure 3). During the first five months of observation (1st Dry season), the rising population sizes of honeybees fed with sugar syrup remained slightly lower than those without sugar

syrup. Thereafter, the population sizes of colonies fed with sugar syrup remained significantly higher ($p < 0.05$) than those that were not fed with sugar syrup which show two distinct unequal peaks between periods of observation (Figure 3). Initially, between November and May, the population sizes of honeybees' colonies with sugar syrup were comparatively low to those colonies without sugar syrup due to the fact that the honeybees were not readily accepting the syrup initially as expected due to surplus nectar and pollen available from the wild in that season. But immediately the wet season became prominent after the month of May, feeding of sugar syrup was meaningful and well accepted by the honeybees because foraging activities probably reduced. Despite the similarities in fluctuation pattern of population sizes of both colonies, honeybees colonies

fed with sugar syrup maintained significant population size throughout the remaining experimental period of 24 months. The results of this study showed that regular feeding of sugar syrup at appropriate time to honeybee colonies for long period (2 years) favoured brood rearing, hence increasing bee population density as observed in the study. The Sugar syrup sustained more population of bees in absence or shortage

of nectars and pollens from the wild in the two wet seasons specifically and probably stimulates brood rearing which led to population increase. It was also observed from this study that regular and appropriate feeding of honeybees in artificial beehives with sugar syrup at appropriate time has steady and positive cumulative effect on bee population (increase in population).

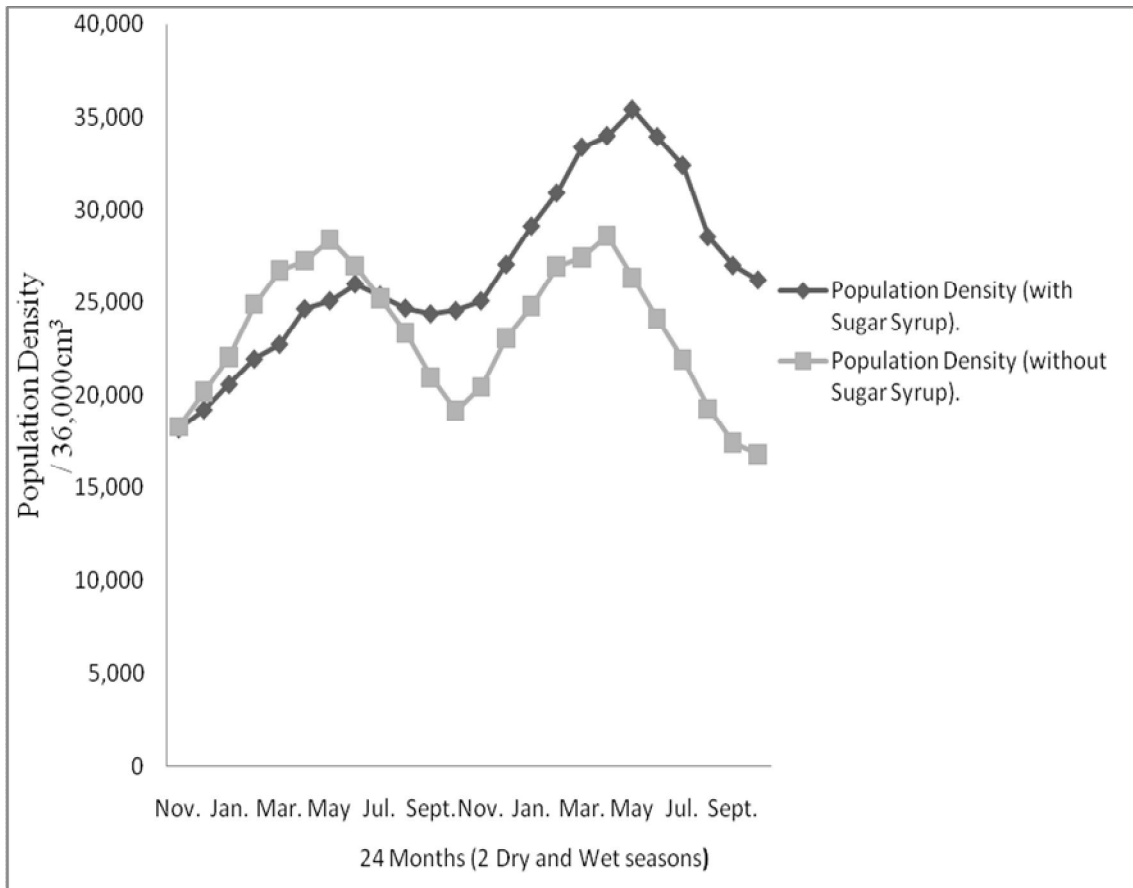

Figure 3: Cumulative effect of sugar syrup on colony size of *Apis mellifera adansonii*

DISCUSSION

Haydak (1970), Johansson and Johansson (1976 and 1977) and Standifer (2005) in United States, Mussen (2005a and b) in California, observed and reported that honeybees fed with nectar and pollen supplements due to inadequate supplies of nectars and pollens from the field during the dearth period, helped bee colonies to be more populous and productive in readiness for nectar flow period immediately after dearth period. Fasasi *et al.*, (2007) reported that administration of sugar syrup to colonies of honeybees (*Apis mellifera adansonii*) in wet season sustained more population of honeybees for foraging activities in the dry season. This significantly increased population and production of bee colonies. Availability of sugar syrup (nectar supplement) in the colony, in absence or shortage of nectars from the wild, stimulated brood production and the worker bees were motivated to nurse their broods and the queen efficiently by feeding and regulating the hive temperature at tolerable level thereby increasing the population density within the colony (Standifer, 2005). Sucrose is a common and highly acceptable artificial food (Foster, 1972; Barker, 1977; Johansson and Johansson, 1977; Barker Lehner, 1978; Winston, 1987 and Singh and Upadhyay, 2008) which stimulates honeybees' colonies to rapid growth. Singh and Upadhyay (2008) reported that mahua syrup successfully provides both carbohydrate and protein to the studied honeybees during lean period. They concluded that mahua syrup appears to be a better substitute than sucrose for feeding bees during lean periods with respect to brood area, number of occupied frames, honey and propolis production and multiplication of colonies. It also significantly increased larval weight, protein and fructose content (Singh and Upadhyay, 2008). This

study does not only confirmed the observations of other authors on pollen supplemental feeding but also showed that continuous feeding of honeybee colonies at every dearth periods has significant positive cumulative effects on the colony size of honeybees. The practical implication of this study is that regular and appropriate feeding of nectar or pollen supplements (such as sugar syrup) to bee colonies for longer duration (Two continuous wet seasons in two years) helps to develop and sustain bee colonies with optimum population for nectar and pollen gathering from the wild specifically during pollen and nectar flow period, hence increasing colony productivity and enhancing crop pollination and colony division when the need arises. It will also enhance fast development and growth of commercial apiary for profitability. This indirectly will boost crop and fruit production to cater for the teaming population. However, in Nigeria this act is rarely practiced among beekeepers probably due to lack of awareness on supplemental feeding. The Beekeepers and Bee farmers are advised and encouraged to feed their bee colonies appropriately and timely to maximize the potentials of their bee colonies.

ACKNOWLEDGEMENT

The author appreciates the suggestions and constructive criticisms of Professors S. L. O. Malaka and Kayode Amund during the research. Special thanks to Prof. Kio. N. Don-Pedro (Late) and Prof. W. A. Makanjuola for editing the article. I am also grateful to Messers O. O. Oworu and D. Mongbe for their technical assistance on the field during the research.

REFERENCES

- Barker, J.** 1977. Some carbohydrates found in pollen and pollen substitutes are toxic to honeybees. *Journal of Nutrition*, 107: 1859 – 1862.
- Farrar, C.L.** 1937. The influence of colony population on honey production. *Journal of Agricultural Research*, 54: 945 – 954.
- Fasasi, K.A., Malaka, S.L.O.** 2005. Seasonal productivity of colonies of honeybees, *Apis mellifera adansonii* (Hymenoptera: Apidae) under natural conditions in Lagos, Nigeria. *Nigerian Journal of Entomology*, 22: 32 – 38.
- Fasasi, K.A., Malaka, S.L.O., Amund, O.O.** 2007. Sugar Syrup as substitute for Nectar: Effect on Production and Density of Honeybee, *Apis mellifera adansonii* (Hymenoptera: Apidae) in artificial beehive. *Nigerian Journal of Entomology*, 24: 48 – 53.
- Fasasi, K.A.** 2008. *Aspects of the Biology of Apis mellifera adansonii* (Hymenoptera: Apidae) with emphasis on Honey and Beeswax production. Ph. D Thesis. 122pp.
- Foster, I. M.** 1972. Feeding sugar to honeybee colonies. *New Zealand Bee keeper*, 34: 15 – 18.
- Fresnaye, J., Lensky, Y.** 1961. Methods appreciation des surfaces de vain Dans les colonies Abeilles. *Ann. Abeille*, 4: 369 – 376.
- Goodwin, R.M., Houten, A.T.** 1979. Feeding sugar syrup to honeybee (*Apis mellifera*) colonies to increase kiwifruit (*Actinidia deliciosa*) pollen collection: effects of frequency, quantity and time of day. *Journal of Apicultural Research*, 30(1): 41 – 48.
- Goodwin, R.M.** 1997. Feeding sugar syrup to honeybees' colonies to improve pollination: a review. *Bee World*, 78(2): 56 – 62.
- Haydak, M.H.** 1970. Honeybee Nutrition. *Annual Review of Entomology*, 15: 143 – 156.
- Johansson, T.S.K., Johansson, M.P.** 1976. Feeding Sugar to Bees. *Bee World*, 57(4): 137 – 142.
- Johansson, T.S.K., Johansson, M.P.** 1977. Feeding Sugar to Bees: When and How to Feed. *Bee World*, 58: 11 – 18.
- Mussen, E.C.** 2005a. *Feeding Bees Pollen Substitutes*. Extension Apiculturist, University of California, Davis. 1pp.
- Mussen, E.C.** 2005b. *Feeding Bees Nectar Substitutes*. Extension Apiculturist, University of California, Davis. 2pp.
- Singh, R.P., Upadhyay, S.K.** 1999. Feeding impacts of flowers' extract of *Bassia latifolia* Roxb (Mahua) on growth and development of bee colony In: *Proceedings XXXVIth International Apicultural congress*, Vancouver, Canada, 12th – 17th September, 1999. 27pp.
- Singh, R.P., Upadhyay, S.K.** 2008. The beneficial effects of feeding mahua (*Bassia latifolia* Roxb) flower syrup to honeybees (*Apis mellifera*) colonies during period of dearth. *Journal of Apicultural Research*, 47(4): 261 – 264.
- Standifer, L.N., Moeller, F.E., Kauffeld, N.M.** 1978. Supplemental feeding of honeybee colonies. U. S. Department of Agriculture. *Agriculture Information Bulletin*, 413: 9.

Standifer, L.N. 2005. *Honey Bee Nutrition and Supplemental Feeding*. United States. 8pp. Beekeeping in the

(Manuscript received: 24th June, 2010; accepted: 9th August, 2011).